

700V/250mΩ Preliminary Datasheet V1.0

Description

This is a 700V GaN-on-Si enhancement-mode power transistor. The properties of GaN allow for high current, high breakdown voltage and high switching frequency.

- Ultra-high switching frequency
- Reverse current capability
- Zero reverse recovery loss
- Monolithic integrated ESD protection
- RoHS, Pb-free, REACH-compliant



Features

- Ultra-low FOM



Table 1 Key Performance Parameters at $T_j = 25\text{ }^\circ\text{C}$

Parameters	Values	Units
$V_{DS, \text{max}}$	700	V
$R_{DS(\text{on}), \text{Typ}}$	250	mΩ

Q_G	1.5	nC
$I_{D, \text{Pulse}}$	10	A
$Q_{OSS} @ 400\text{ V}$	13	nC
Q_{rr}	0	nC

- Bridgeless totem pole PFC
- Fast chargers
- Power adapters
- LED lighting drivers
- Wireless power transfer
- Laser drivers • TV display

Applications

- AC/DC converters
- DC/DC converters

Table2 Ordering Information

Ordering Code	Package	Product code
GP70R250T2P	TO220FP	GP70R250T2P

Table of contents

Description.....	1
Features	1
Applications.....	1
Table of contents.....	2
1 Maximum ratings.....	2
2 Electrical characteristics.....	3
3 Electrical characteristics diagrams	5
4 Package Information.....	11
5 Revision history	12

1 Maximum ratings

at $T_j = 25\text{ °C}$ unless otherwise specified. Continuous application of maximum ratings can deteriorate transistor lifetime.

Table 3 Maximum rating

Parameters	Symbols	Values	Units	Notes/Test Conditions
Drain-source voltage	$V_{DS, max}$	700	V	$V_{GS} = 0\text{ V}$ $T_j = -55\text{ °C to }150\text{ °C}$
Drain-source voltage transient ¹	$V_{DS, transient}$	800	V	$V_{GS} = 0\text{ V}$
Continuous current, drain-source	I_D	6	A	$T_c = 25\text{ °C}$
Pulsed current, drain-source ²	$I_{D, pulse}$	10	A	$T_c = 25\text{ °C}; V_G = 6\text{ V}$
Pulsed current, drain-source ²	$I_{D, pulse}$	6	A	$T_c = 125\text{ °C}; V_G = 6\text{ V}$

Gate-source voltage, continuous	V_{GS}	-6 to +20	V	$T_j = -55\text{ °C to }150\text{ °C}$
Gate-source voltage, pulsed	$V_{GS, pulse}$	-20 to +20	V	$T_j = -55\text{ °C to }150\text{ °C}$; $t_{Pulse} = 50\text{ ns}$, $f = 100\text{ kHz}$; open drain
Power dissipation	P_{tot}	50	W	$T_c = 25\text{ °C}$
Operating temperature	T_j	-55 to +150	°C	
Storage temperature	T_{stg}	-55 to +150	°C	

- $V_{DS, transient}$ is intended for surge rating during non-repetitive events, $t_{Pulse} < 1\text{ }\mu\text{s}$.
- Pulse width = 10 μs .

2 Electrical characteristics

at $T_j = 25\text{ °C}$, unless specified otherwise.

Table 4 Static characteristics

Parameters	Symbols	Values			Units	Notes/Test Conditions
		Min.	Typ.	Max.		
Gate threshold voltage	$V_{GS(TH)}$	2.0	2.6	3.5	V	$I_D = 6\text{ mA}$; $V_{DS} = V_{GS}$; $T_j = 25\text{ °C}$
		-	3	-		$I_D = 6\text{ mA}$; $V_{DS} = V_{GS}$; $T_j = 150\text{ °C}$
Drain-source leakage current	I_{DSS}	-	0.01	0.6	μA	$V_{DS} = 700\text{ V}$; $V_{GS} = 0\text{ V}$; $T_j = 25\text{ °C}$
		-	0.6	-		$V_{DS} = 700\text{ V}$; $V_{GS} = 0\text{ V}$; $T_j = 150\text{ °C}$
Gate-source leakage current	I_{GSS}	-	2	-	mA	$V_{GS} = 6\text{ V}$; $V_{DS} = 0\text{ V}$
Drain-source on-state Resistance ¹	$R_{DS(on)}$	-	250	310	mΩ	$V_{GS} = 6\text{ V}$; $I_D = 2.2\text{ A}$; $T_j = 25\text{ °C}$
		-	590	-	mΩ	$V_{GS} = 6\text{ V}$; $I_D = 2.2\text{ A}$; $T_j = 150\text{ °C}$
Gate resistance	R_G	-	11	-	Ω	$f = 5\text{ MHz}$; open drain

1. $R_{DS(on)}$ is the test of fresh devices

Table 5 Dynamic characteristics

Parameters	Symbols	Values			Units	Notes/Test Conditions
		Min.	Typ.	Max.		
Input capacitance	C_{iss}	-	50	-	pF	$V_{GS} = 0\text{ V}$; $V_{DS} = 400\text{ V}$; $f = 100\text{ KHZ}$

Output capacitance	C_{oss}	-	15	-	pF	$V_{GS} = 0\text{ V}; V_{DS} = 400\text{ V}; f = 100\text{ KHZ}$
Reverse transfer capacitance	C_{rss}	-	0.2	-	pF	$V_{GS} = 0\text{ V}; V_{DS} = 400\text{ V}; f = 100\text{ KHZ}$
Effective output capacitance, energy related ¹	$C_{o(er)}$	-	17	-	pF	$V_{GS} = 0\text{ V}; V_{DS} = 0\text{ to }400\text{ V}$
Effective output capacitance, time related ²	$C_{o(tr)}$	-	24	-	pF	$V_{GS} = 0\text{ V}; V_{DS} = 0\text{ to }400\text{ V}$
Output charge	Q_{oss}	-	11	-	nC	$V_{GS} = 0\text{ V}; V_{DS} = 0\text{ to }400\text{ V}$
Turn-on delay time	$t_{d(on)}$	-	0.9	-	ns	$V_{DS} = 400\text{ V}; I_D = 4.4\text{ A}; L = 318\text{ }\mu\text{H};$ $V_{GS} = 6\text{ V}; R_{on} = 10\text{ }\Omega; R_{off} = 2\text{ }\Omega$
Turn-off delay time	$t_{d(off)}$	-	1.2	-	ns	
Rise time	t_r	-	3.5	-	ns	
Fall time	t_f	-	6.1	-	ns	

- $C_{o(er)}$ is the fixed capacitance that gives the same stored energy as C_{oss} while V_{DS} is rising from 0 to 400 V.
- $C_{o(tr)}$ is the fixed capacitance that gives the same charging time as C_{oss} while V_{DS} is rising from 0 to 400 V.

Table 6 Gate charge characteristics

Parameters	Symbols	Values			Units	Notes/Test Conditions
		Min.	Typ.	Max.		
Gate charge	Q_G	-	1.5	-	nC	$V_{GS} = 0\text{ to }6\text{ V}; V_{DS} = 400\text{ V};$ $I_D = 2.2\text{ A}$
Gate-source charge	Q_{GS}	-	0.15	-	nC	
Gate-drain charge	Q_{GD}	-	0.5	-	nC	
Gate plateau voltage	V_{plat}	-	2.5	-	V	$V_{DS} = 400\text{ V}; I_D = 2.2\text{ A}$

Table 7 Reverse conduction characteristics

Parameters	Symbols	Values			Units	Notes/Test Conditions
		Min.	Typ.	Max.		
Source-drain reverse voltage	V_{SD}	-	4	-	V	$V_{GS} = 0\text{ V}; I_{SD} = 2.2\text{ A}$
Pulsed current, reverse	$I_{S, pulse}$	-	-	10	A	$V_{GS} = 6\text{ V}$
Reverse recovery charge ¹	Q_{rr}	-	0	-	nC	$I_{SD} = 2.2\text{ A}; V_{DS} = 400\text{ V}$
Reverse recovery time	t_{rr}	-	0	-	ns	

Peak reverse recovery current	I_{rrm}	-	0	-	A	
-------------------------------	-----------	---	---	---	---	--

1. Excluding Q_{oss}

3 Electrical characteristics diagrams

at $T_j = 25\text{ °C}$, unless specified otherwise.

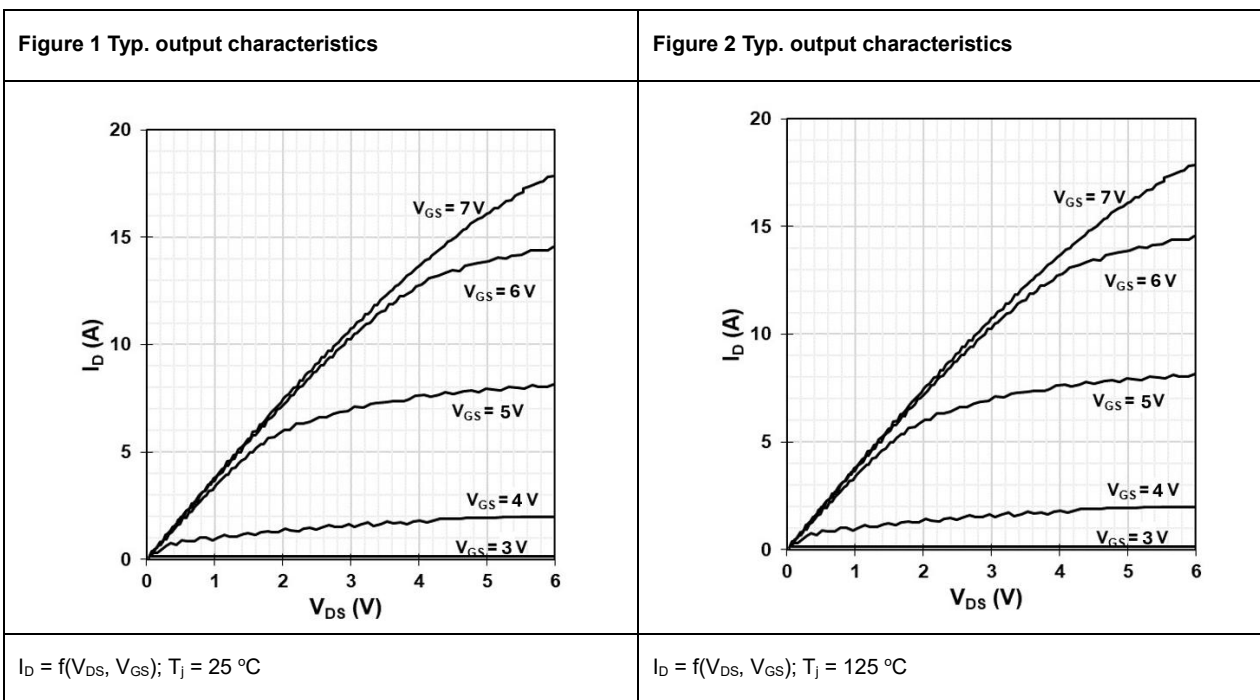

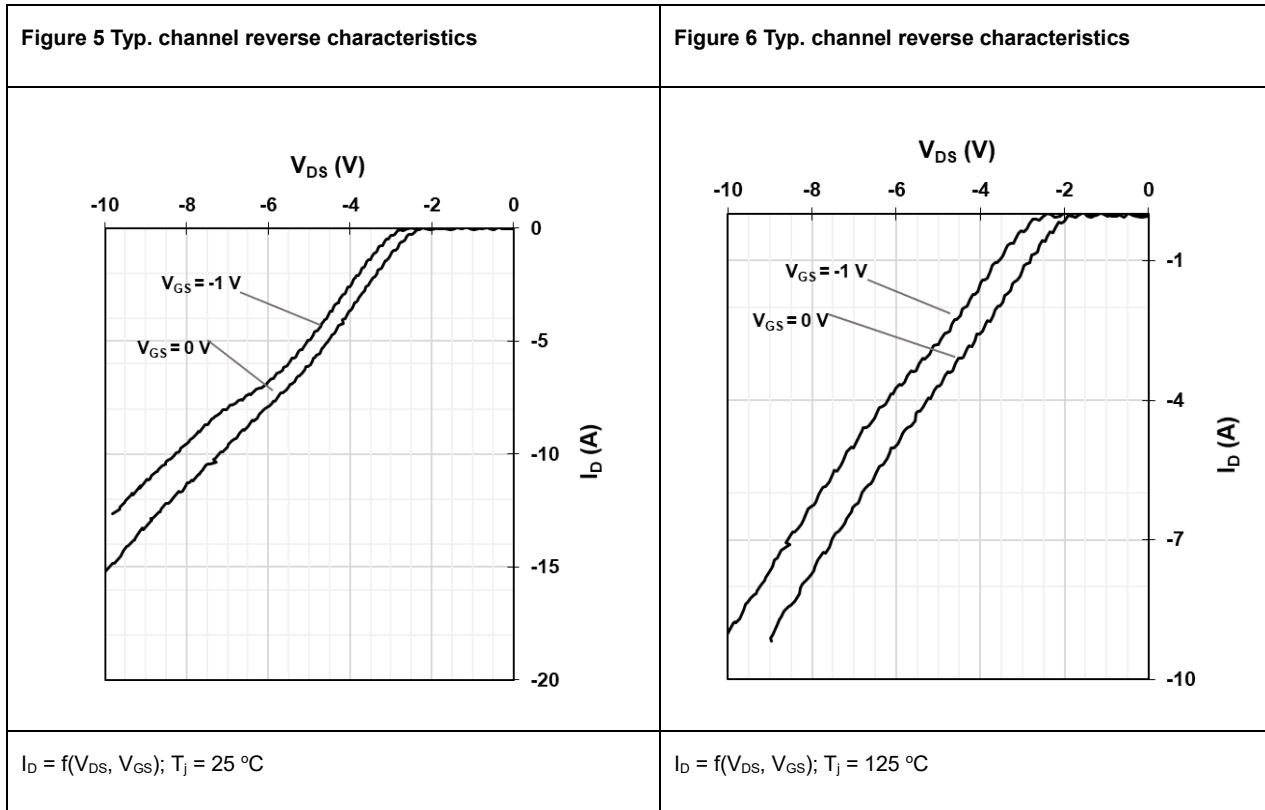
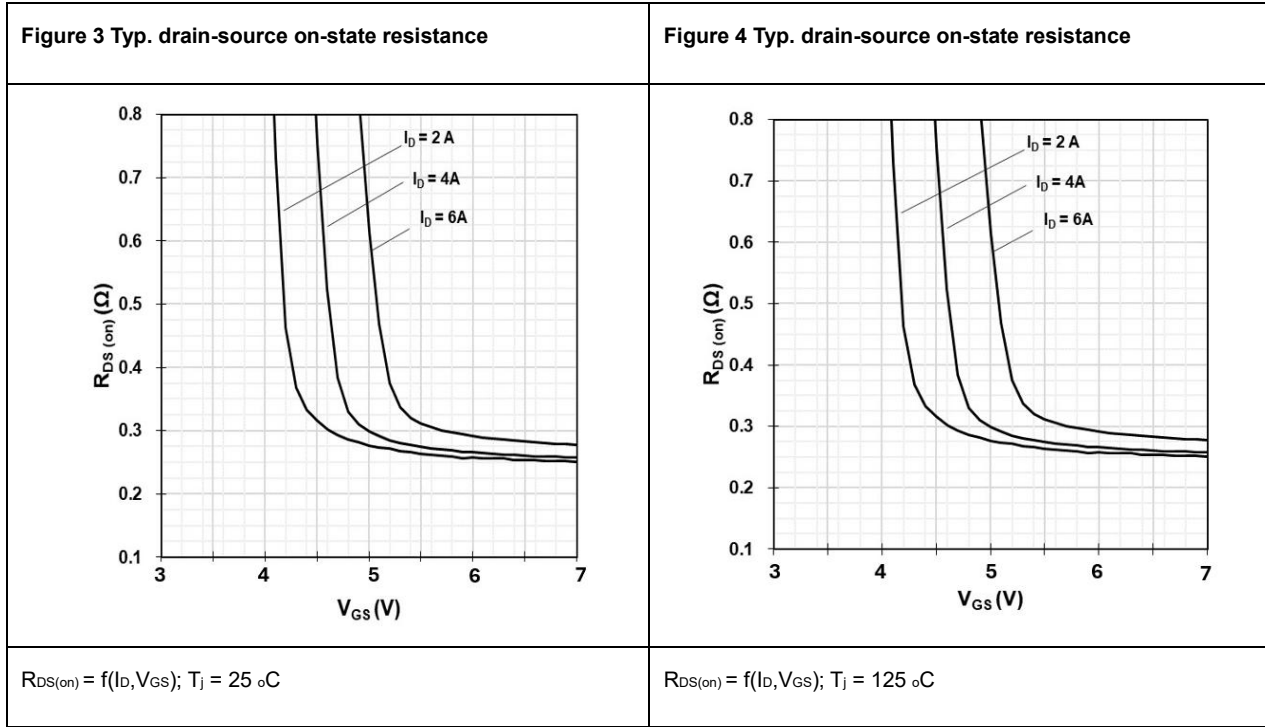

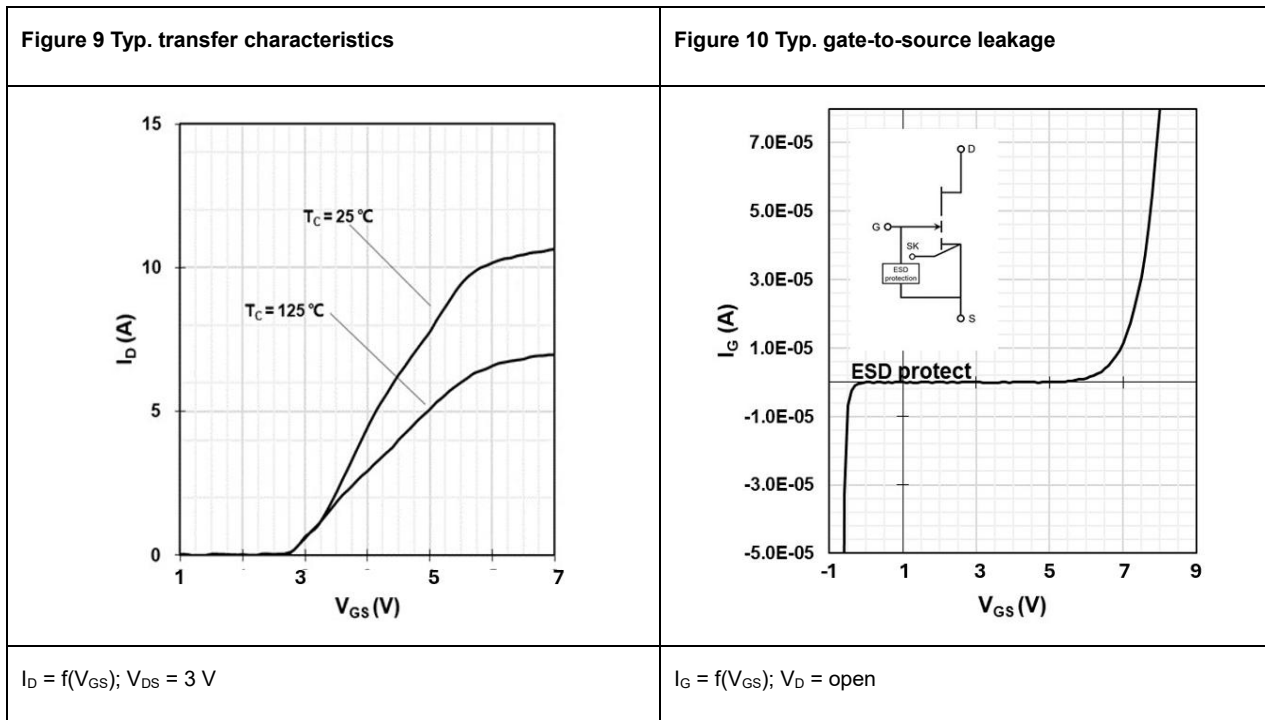
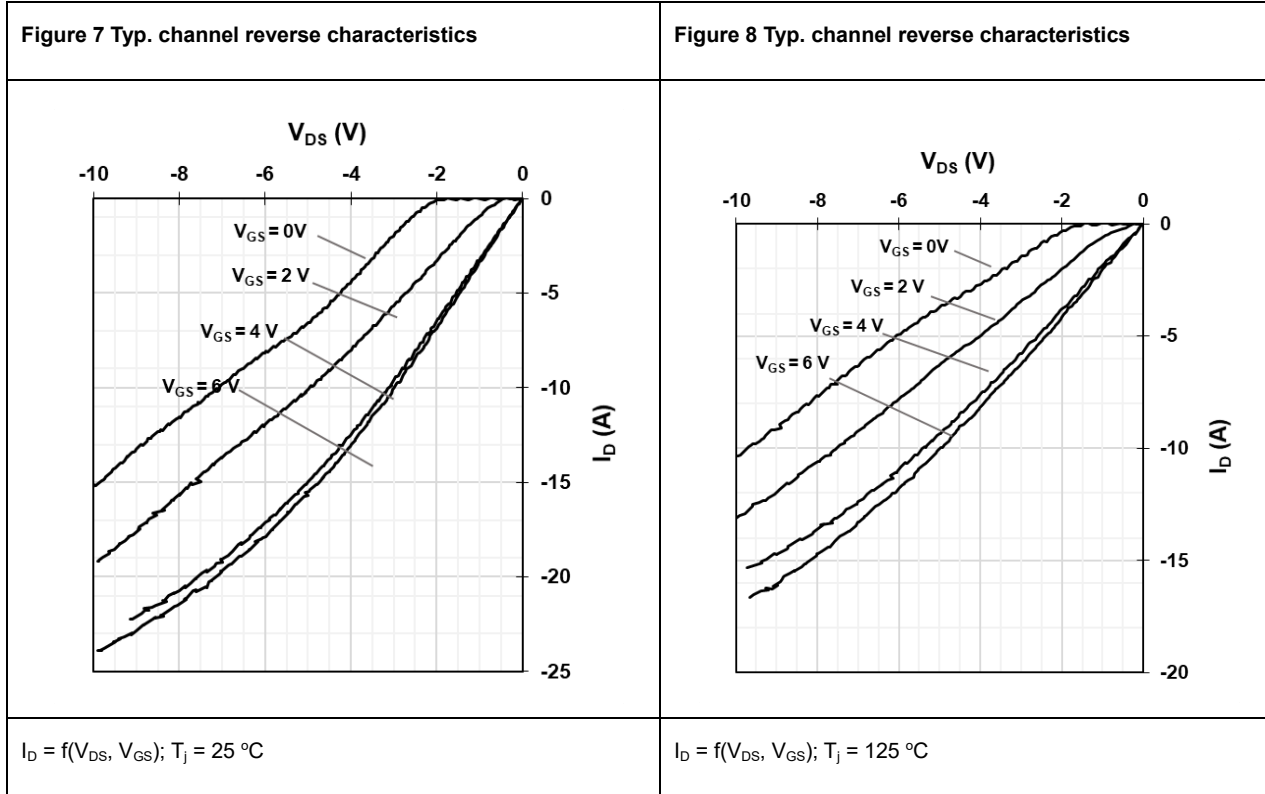
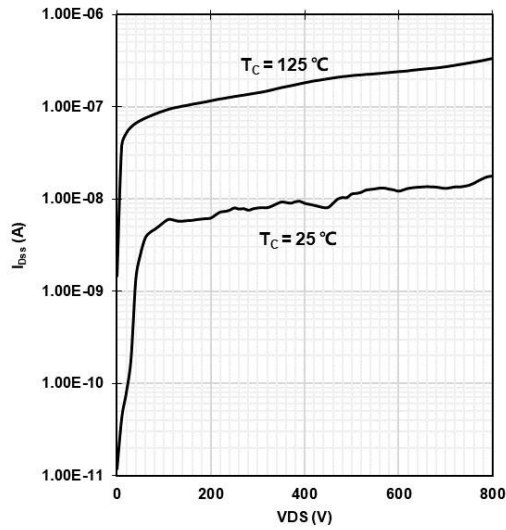
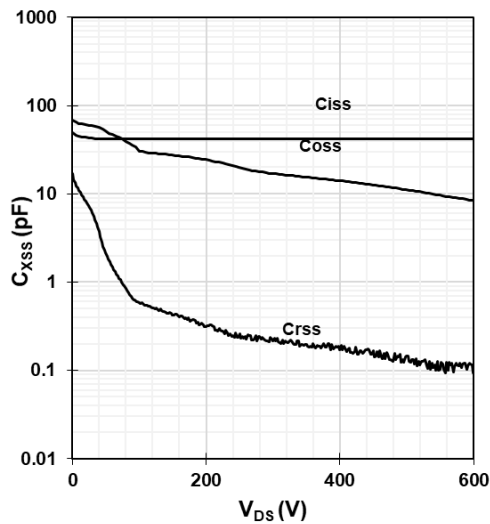

Figure 11 Drain-source leakage characteristics



$I_{dss} = f(V_{ds}); V_{gs} = 0V$

Figure 12 Typ. capacitances



$C_{xss} = f(V_{DS}); \text{Freq.} = 100\text{kHz}$

Figure 13 Typ. gate charge

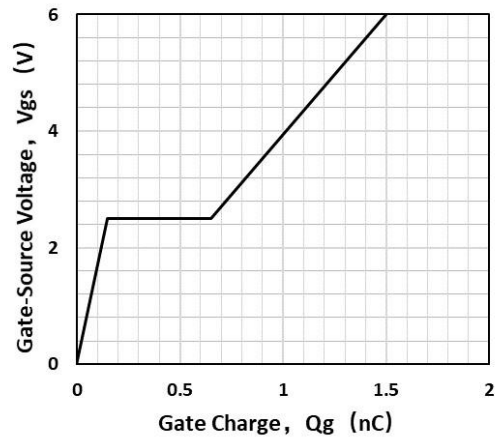

$V_{GS} = f(Q_G); V_{DS} = 400\text{V}; I_D = 2.2\text{A}$

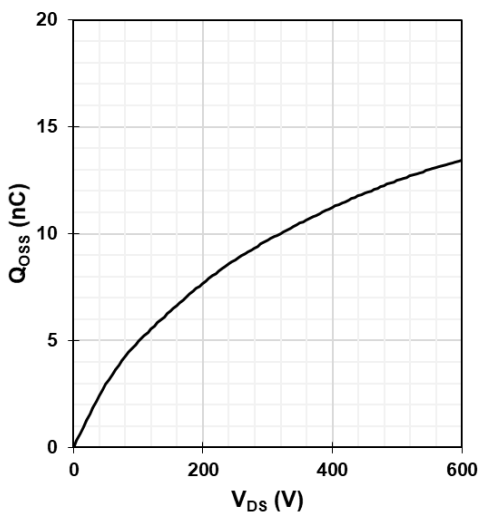
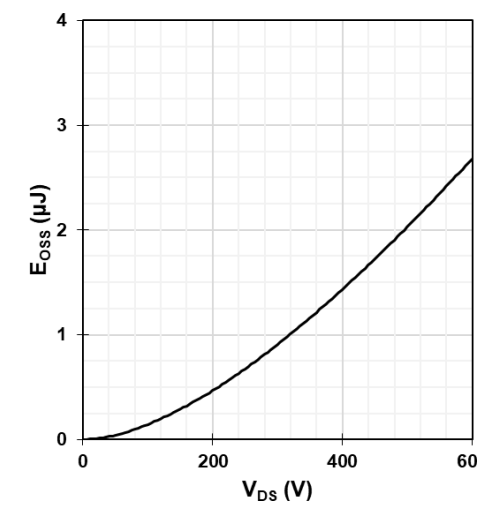
<p>Figure 14 Typ. output charge</p>	<p>Figure 15 Typ. C_{OSS} stored energy</p>																																
 <table border="1"> <caption>Data for Figure 14: Typ. output charge</caption> <thead> <tr> <th>V_{DS} (V)</th> <th>Q_{OSS} (nC)</th> </tr> </thead> <tbody> <tr><td>0</td><td>0</td></tr> <tr><td>100</td><td>5.5</td></tr> <tr><td>200</td><td>8.5</td></tr> <tr><td>300</td><td>10.5</td></tr> <tr><td>400</td><td>12.0</td></tr> <tr><td>500</td><td>13.0</td></tr> <tr><td>600</td><td>13.5</td></tr> </tbody> </table>	V _{DS} (V)	Q _{OSS} (nC)	0	0	100	5.5	200	8.5	300	10.5	400	12.0	500	13.0	600	13.5	 <table border="1"> <caption>Data for Figure 15: Typ. C_{OSS} stored energy</caption> <thead> <tr> <th>V_{DS} (V)</th> <th>E_{OSS} (μJ)</th> </tr> </thead> <tbody> <tr><td>0</td><td>0</td></tr> <tr><td>100</td><td>0.2</td></tr> <tr><td>200</td><td>0.5</td></tr> <tr><td>300</td><td>1.0</td></tr> <tr><td>400</td><td>1.6</td></tr> <tr><td>500</td><td>2.2</td></tr> <tr><td>600</td><td>2.7</td></tr> </tbody> </table>	V _{DS} (V)	E _{OSS} (μJ)	0	0	100	0.2	200	0.5	300	1.0	400	1.6	500	2.2	600	2.7
V _{DS} (V)	Q _{OSS} (nC)																																
0	0																																
100	5.5																																
200	8.5																																
300	10.5																																
400	12.0																																
500	13.0																																
600	13.5																																
V _{DS} (V)	E _{OSS} (μJ)																																
0	0																																
100	0.2																																
200	0.5																																
300	1.0																																
400	1.6																																
500	2.2																																
600	2.7																																
<p>Q_{OSS} = f(V_{DS}); Freq. = 100kHz</p>	<p>E_{OSS} = f(V_{DS}); Freq. = 100kHz</p>																																

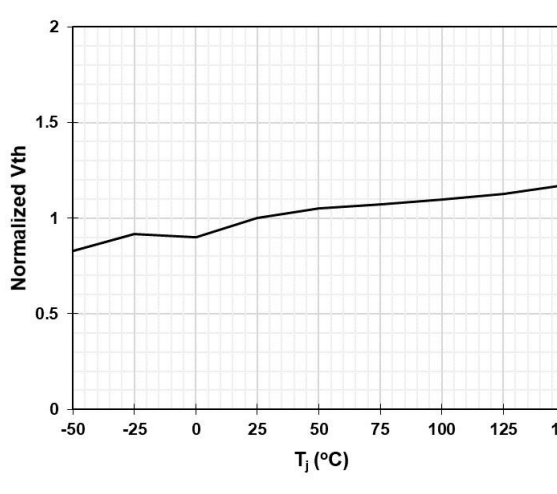
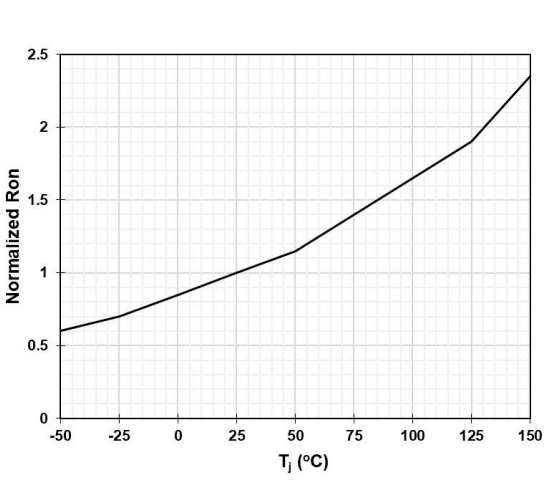
<p>Figure 16 Gate threshold voltage</p>	<p>Figure 17 Drain-source on-state resistance</p>																																								
 <table border="1"> <caption>Data for Figure 16: Gate threshold voltage</caption> <thead> <tr> <th>T_j (°C)</th> <th>Normalized V_{th}</th> </tr> </thead> <tbody> <tr><td>-50</td><td>0.85</td></tr> <tr><td>-25</td><td>0.90</td></tr> <tr><td>0</td><td>0.90</td></tr> <tr><td>25</td><td>1.00</td></tr> <tr><td>50</td><td>1.05</td></tr> <tr><td>75</td><td>1.08</td></tr> <tr><td>100</td><td>1.10</td></tr> <tr><td>125</td><td>1.12</td></tr> <tr><td>150</td><td>1.15</td></tr> </tbody> </table>	T _j (°C)	Normalized V _{th}	-50	0.85	-25	0.90	0	0.90	25	1.00	50	1.05	75	1.08	100	1.10	125	1.12	150	1.15	 <table border="1"> <caption>Data for Figure 17: Drain-source on-state resistance</caption> <thead> <tr> <th>T_j (°C)</th> <th>Normalized R_{on}</th> </tr> </thead> <tbody> <tr><td>-50</td><td>0.6</td></tr> <tr><td>-25</td><td>0.7</td></tr> <tr><td>0</td><td>0.8</td></tr> <tr><td>25</td><td>0.95</td></tr> <tr><td>50</td><td>1.15</td></tr> <tr><td>75</td><td>1.4</td></tr> <tr><td>100</td><td>1.7</td></tr> <tr><td>125</td><td>2.0</td></tr> <tr><td>150</td><td>2.4</td></tr> </tbody> </table>	T _j (°C)	Normalized R _{on}	-50	0.6	-25	0.7	0	0.8	25	0.95	50	1.15	75	1.4	100	1.7	125	2.0	150	2.4
T _j (°C)	Normalized V _{th}																																								
-50	0.85																																								
-25	0.90																																								
0	0.90																																								
25	1.00																																								
50	1.05																																								
75	1.08																																								
100	1.10																																								
125	1.12																																								
150	1.15																																								
T _j (°C)	Normalized R _{on}																																								
-50	0.6																																								
-25	0.7																																								
0	0.8																																								
25	0.95																																								
50	1.15																																								
75	1.4																																								
100	1.7																																								
125	2.0																																								
150	2.4																																								
<p>V_{GS(TH)} = f(T_j); V_{GS} = V_{DS}; I_D = 6 mA</p>	<p>R_{DS(on)} = f(T_j); I_D = 2.2 A; V_{GS} = 6 V</p>																																								

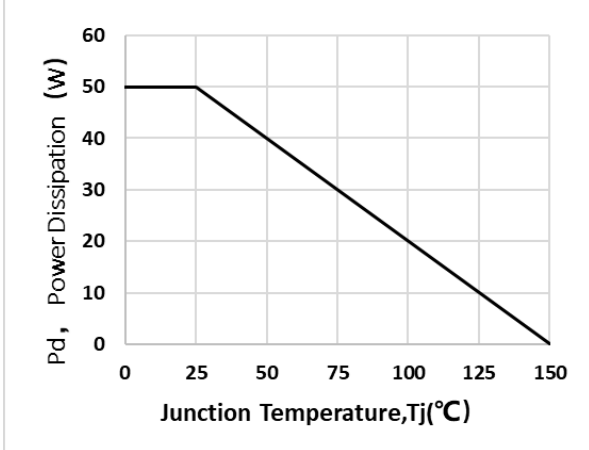
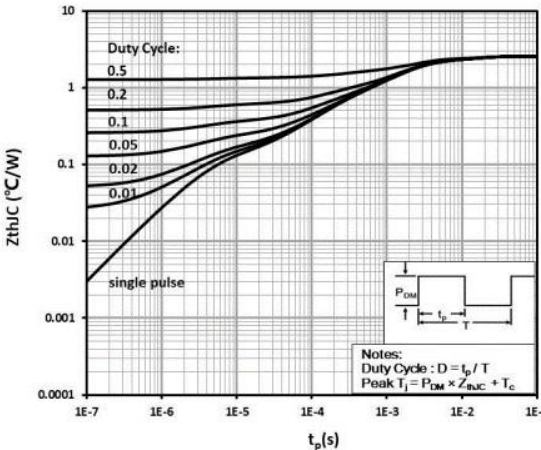
<p>Figure 18 Power dissipation</p>	<p>Figure 19 Max.transient thermal impedance</p>
	
<p>$P_{tot} = f(T_c)$</p>	<p>$Z_{thjC} = f(t_p, D)$</p>

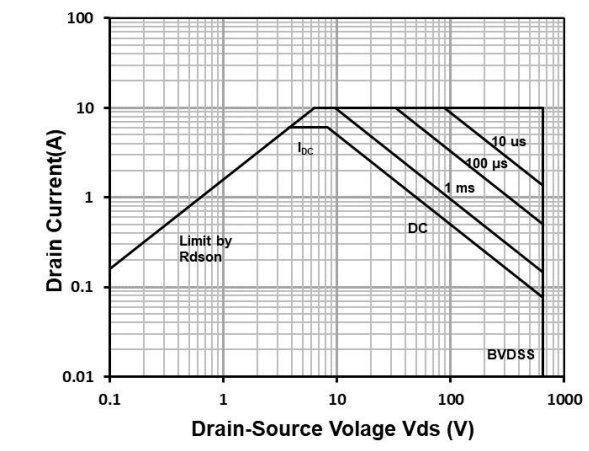
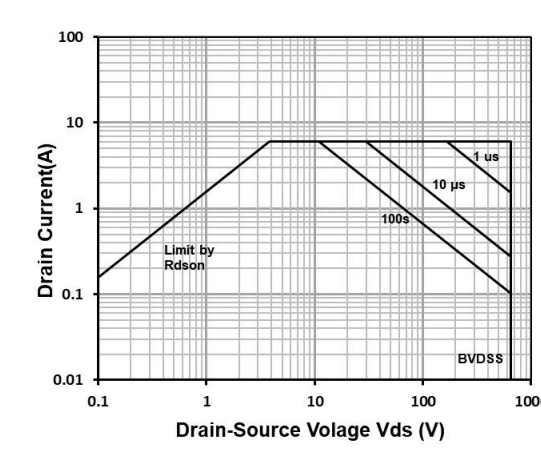
<p>Figure 20 Safe Operation Area</p>	<p>Figure 21 Safe Operation Area</p>
	
<p>$I_d = f(V_{ds}); T_c = 25^\circ\text{C}$</p>	<p>$I_d = f(V_{ds}); T_c = 125^\circ\text{C}$</p>

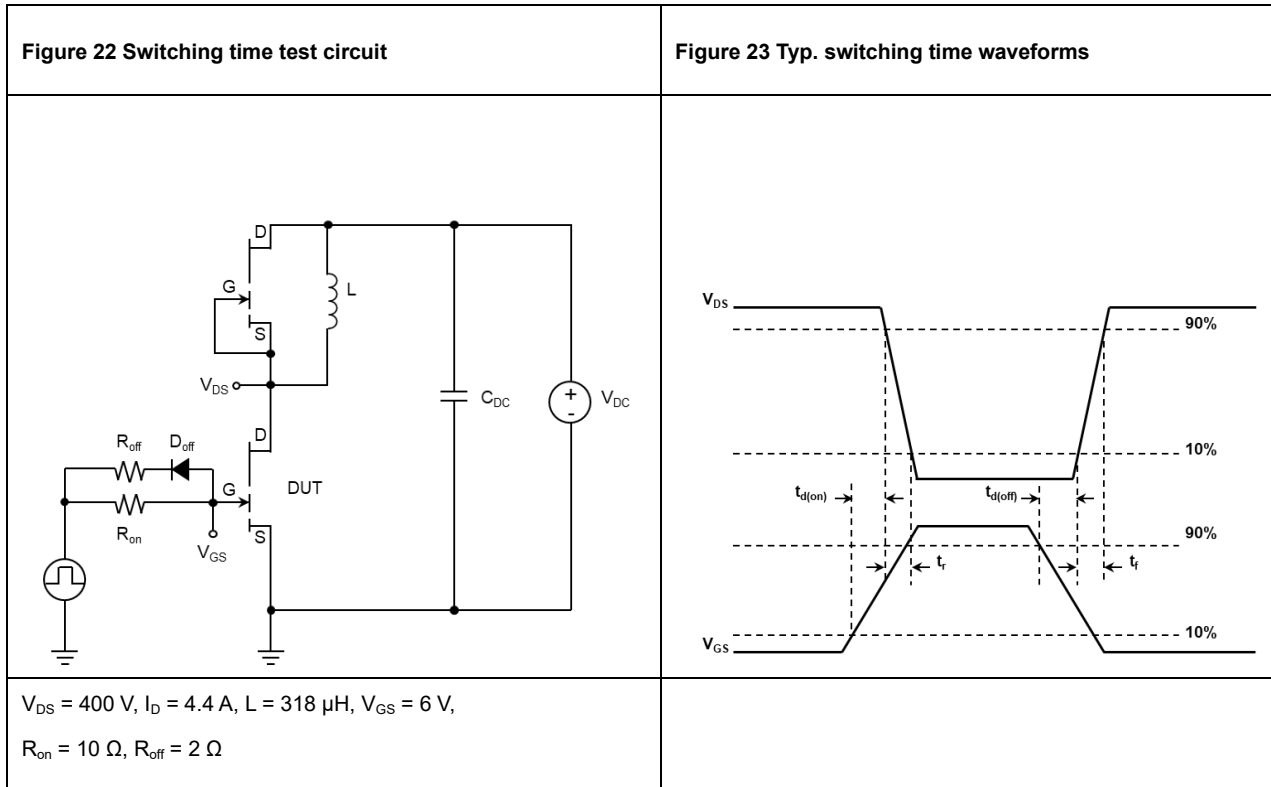

4 Package Information

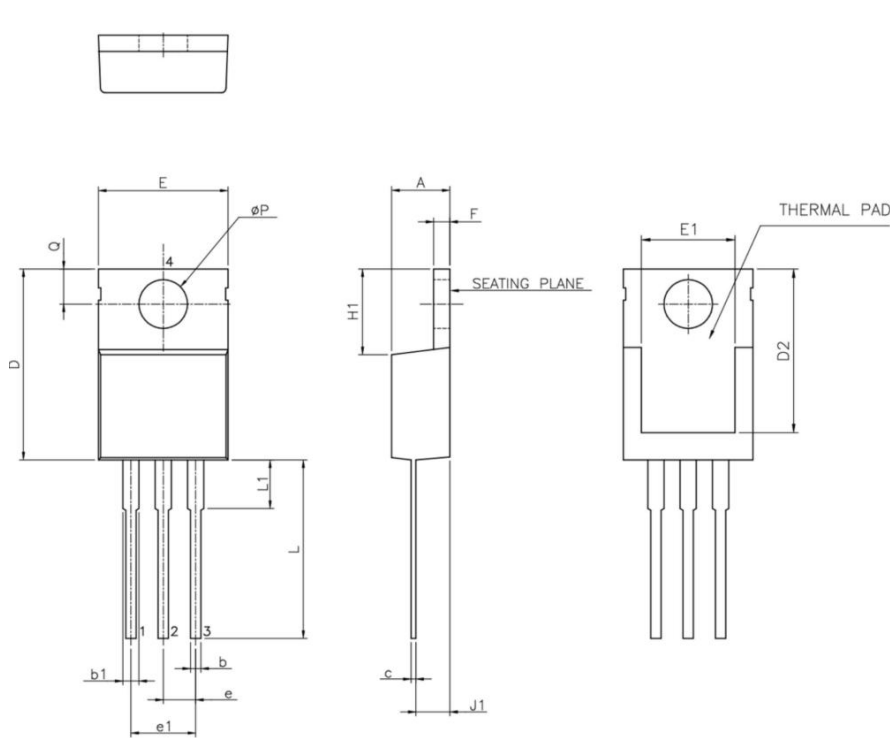

VARIATIONS (ALL DIMENSIONS SHOWN IN MM)

SYMBOLS	MIN.	MAX.
A	3.56	4.82
b1	1.15	1.77
b	0.38	1.01
c	0.35	0.61
D	14.23	16.51
E	9.66	10.66
D2	11.75	11.90
E1	6.86	8.90
e	2.29	2.79
e1	4.83	5.33
F	0.51	1.39
H1	5.85	6.85
J1	2.04	2.92
L	12.70	14.73
φP	3.54	4.08
Q	2.54	3.42
L1	3.65	6.35

NOTES:
1. JEDEC OUTLINE : N/A.

5 Revision history

Major changes since the last revision

Revision	Date	Description of changes
1.0	2026-04-27	Initial version release

6 Further Information

Important Notice—Unless expressly approved in writing by an authorized representative of GaNPower, GaNPower components are not designed, authorized or warranted for use in lifesaving, life sustaining, military, aircraft, or space applications, nor in products or systems where failure or malfunction may result in personal injury, death, or property or environmental damage. The information given in this document shall not in any event be regarded as a guarantee of performance. GaNPower hereby disclaims any or all warranties and liabilities of any kind, including but not limited to warranties of non-infringement of intellectual property rights. All other brand and product names are trademarks or registered trademarks of their respective owners. Information provided herein is intended as a guide only and is subject to change without notice. The information contained herein or any use of such information does not grant, explicitly, or implicitly, to any party any patent rights, licenses, or any other intellectual property rights. All rights reserved.

Data Source– Data here are based on recent tests but all parameters may not be up to date. Actual final test data from packaging production are available for selected customers upon request.